

HMC

HYDRAULIC JACKS

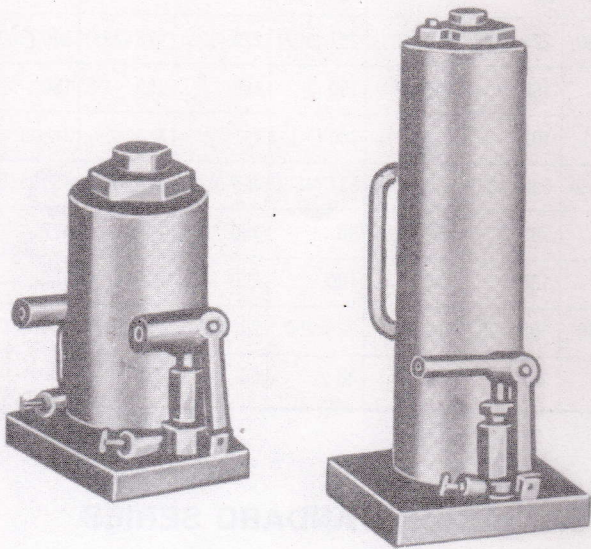

GENERAL PURPOSE BOTTLE TYPE JACKS
with Integral Pump

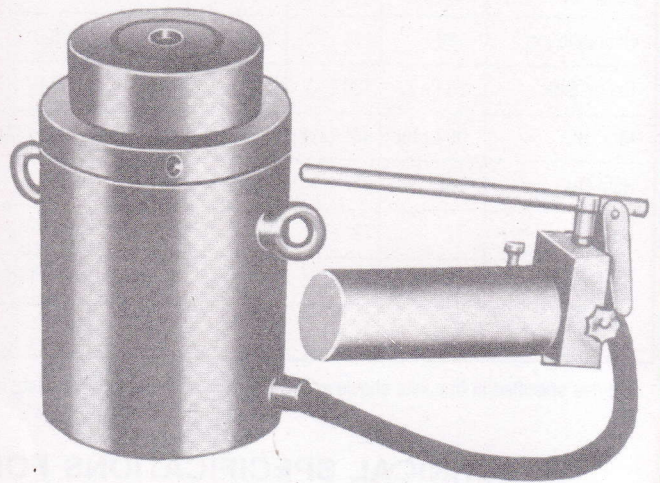

PLAIN RAM TYPE HYDRAULIC JACKS
with Remote Pump

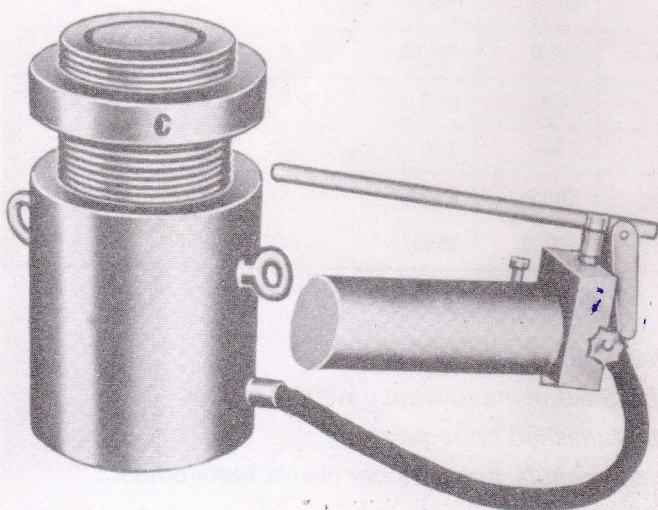

SCREW RAM TYPE HYDRAULIC JACKS
with Remote Pump

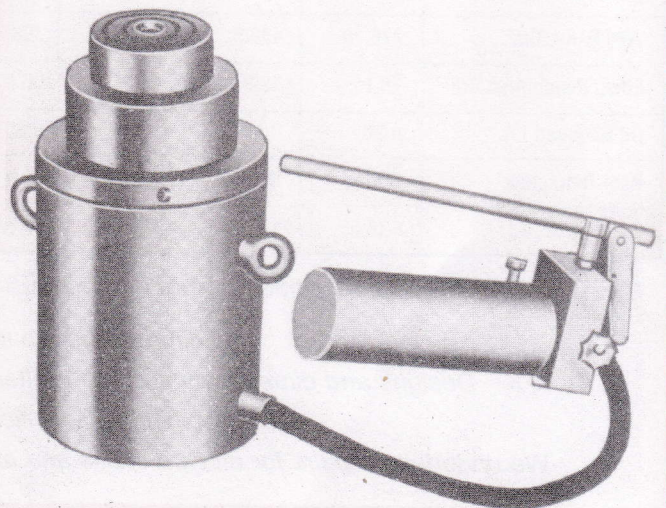

TELESCOPIC TYPE HYDRAULIC JACKS
with Remote Pump



HYDRAULIC JACKS

TECHNICAL SPECIFICATIONS FOR HYDRAULIC JACKS STANDARD SERIES PLAIN RAM / SCREWED RAM WITH SAFETY LOCK NUT CAPACITY 2 TO 100 TONS

Capacity in Tons	2	5	8	10	12	15	20	25	30	40	50	75	100
Minimum Ht.	199 (216)	231 (248)	236 (248)	236 (252)	236 (252)	250 (260)	250 (260)	270 (285)	270 (285)	287 (307)	275 (325)	275 (325)	300 (360)
Hydraulic Lift	120	150	150	150	150	150	150	150	150	150	150	150	150
Screw Extn.	75 (-)	100 (-)	100 (-)	100 (-)	100 (-)	100 (-)	100 (-)	100 (-)	100 (-)	100 (-)	X	X	X
Max. Ht.	394 (336)	481 (398)	486 (402)	486 (402)	486 (402)	500 (410)	500 (410)	520 (435)	520 (435)	537 (457)	425 (475)	425 (475)	450 (510)
Ram Dia.	36	36	43	46	52	58	65	70	76	90	100	110	127
Body Dia.	72	72	86	90	98	112	126	138	146	180	200	215	235
Base Size	125x125	125x125	150x140	150x150	150x150	170x170	180x180	190x190	200x200	225x250	240x300	255x315	280x330
Wt. Approx. Kg	6	8	10	11	12	16.5	22	26	29	36	56	75	90

Figures specified in brackets shows variations for screwed ram with safety lock nut

TECHNICAL SPECIFICATIONS FOR HYDRAULIC JACKS STANDARD SERIES REMOTE CONTROL PLAIN RAM WITH SAFETY LOCK NUT CAPACITY 5 TO 100 TONS

Capacity in Tons	5	10	15	20	25	30	40	50	75	100
Closed Ht.	230 (255)	240 (261)	270 (300)	275 (305)	280 (310)	285 (315)	300(350)	315(365)	315 (365)	320 (385)
Hydraulic Lift	150	150	150	150	150	150	150	150	150	150
Extended Height	380 (405)	390 (411)	420 (450)	425 (455)	430 (460)	435 (465)	450 (500)	465 (515)	465 (515)	470 (535)
Body Dia	63	80	100	110	115	127	145	158	195	235
Ram Dia	46	50	67	73	76	90	100	115	125	155
Wkg.P. Kg./Cm ²	276.20	436.5	358.5	398	440.7	397.9	461.80	407.6	424.3	415.6
Effec. Piston Area Cm ²	18.1	22.9	41.8	50.2	56.7	75.4	86.6	122.6	176.8	240.6
Oil Required Lit.	0.30	0.50	0.70	0.80	1.00	1.25	1.40	2	3	3.7
Ram Retraction	Spring	Spring	Spring	Spring	Spring	Spring	Spring	Spring	Spring	Spring
Wt. Approx. Kg.	6 (6.5)	12 (13)	15 (16)	18 (20)	22 (24)	26 (29)	35 (37)	46 (48)	72 (74)	95 (98)

Figures specified in brackets shows variations for screwed ram with safety lock nut

All dimensions are in mm unless otherwise stated.

Designs and dimensions subject to alteration for the Sake of improvement without notice.

Telescopic Jack Specification can be furnished on request.

We undertake repairs for all type Jacks and also Undertake manufacturing as per clients requirement.

HEMCO CORPORATION

308, PERIN NARIMAN STREET, BEHIND RESERVE BANK OF INDIA, POST BOX NO. 1645,
FORT, MUMBAI - 400 001. PHONE : 2266 3828, 2267 3162, FAX NO. 2267 3162
E-mail : hemco@bom8.vsnl.net.in / hemcodeepak@yahoo.com website : www.hemcohydraulics.com

HMC

HYDRAULIC TEST PUMP

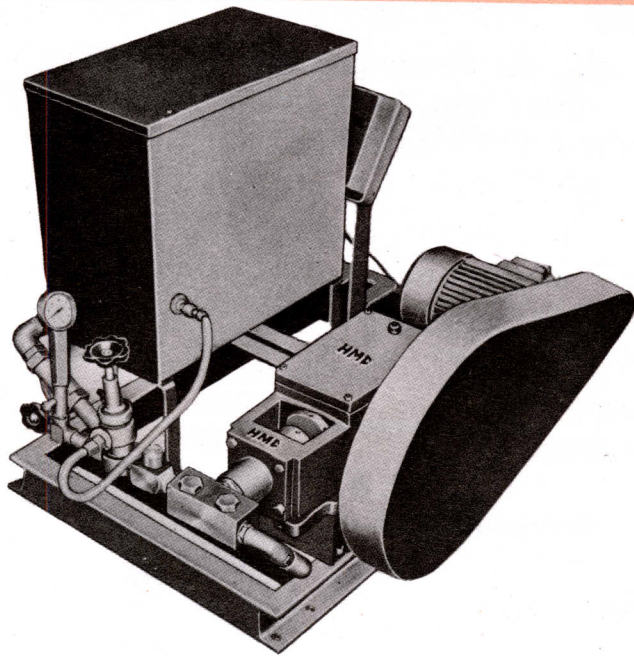

'HMC' Motorised Hydraulic pressure Test pump complete with Electric Motor, Single Piston pump, Pressure Gauge, Tank outlet and mounted on a solid M.S. Trolley.

HMC-MOTORISED HYDRAULIC PRESSURE TEST PUMP

Pressure in Kg/cm ²	Pressure in PSI	H.P.	Discharge L.P. Hour
70	1000	1	120
140	2000	2	120
210	3000	3	120
350	5000	5	120
700	10000	7.5	80-100
1000	14000	10	80-100

MATERIAL SPECIFICATION

Frame	:M.S.
Tank	:M.S.
Electric Motor	:comm.
V-Belt drive	:comm.
Piston	:Alloy Steel
Crank	:Alloy Steel
Check Valve	:AISI-410
Strainer	:Brass
P.R.V.	:Brass
Control Valve	:Brass
Gauge	:comm.
Drainage	:C-S

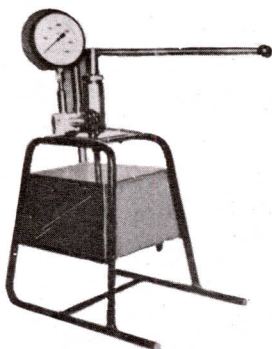

HMC - Hydraulic Pressure Test pump.

(Hand Operated)

HMC - Hydraulic Hand operated pressure Test pump complete with pressure guage, check valve, Pressure Release Valve, Stand, Tank and Handle

Pressure in PS I	Pressure in 4 Kg/cm ²
1000	70
2000	140
3000	210
5000	350
5800	400
8000	560
10000	700
14000	1000

HEMCO CORPORATION

308, PERIN NARIMAN STREET, BEHIND RESERVE BANK OF INDIA, POST BOX NO. 1645,
MUMBAI - 400 001. GRAMS : HEMCORP, PHONE : 2266 3828, 2267 3162, FAX NO. 2267 3162
E-mail : hemco@bom8.vsnl.net.in / website : www.hemcohydraulics.com

HYDROBEND

HYDRAULIC PIPE BENDING MACHINES

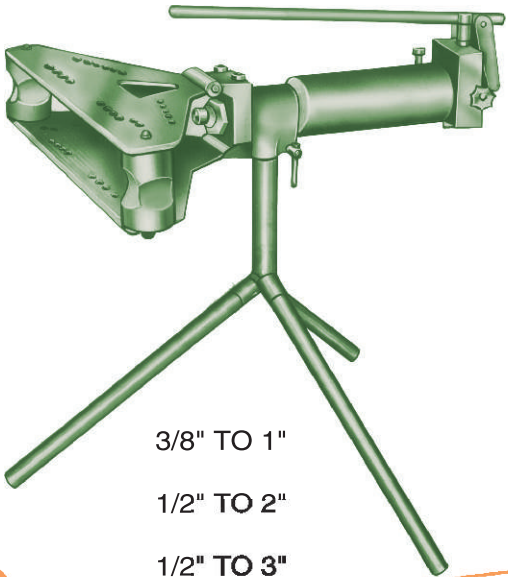

3/8" TO 1"
1/2" TO 2"
1/2" TO 3"

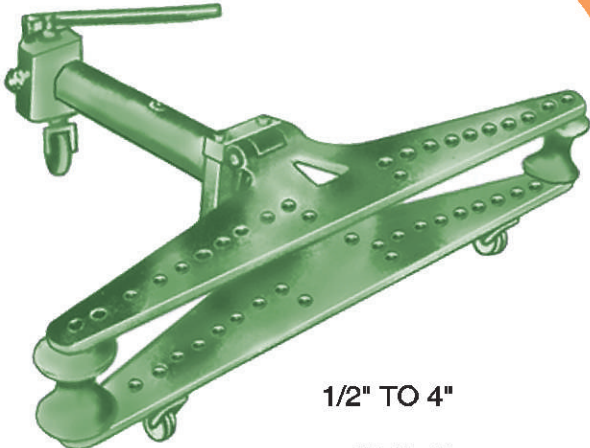

1/2" TO 4"
1" TO 4"
2" TO 6"

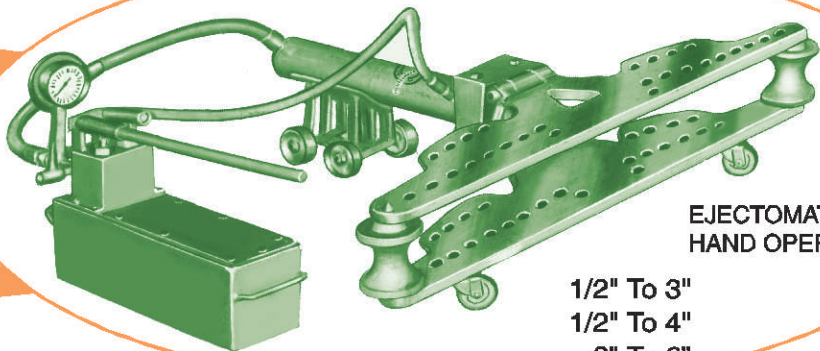

EJECTOMATIC
HAND OPERATED

1/2" To 3"
1/2" To 4"
2" To 6"

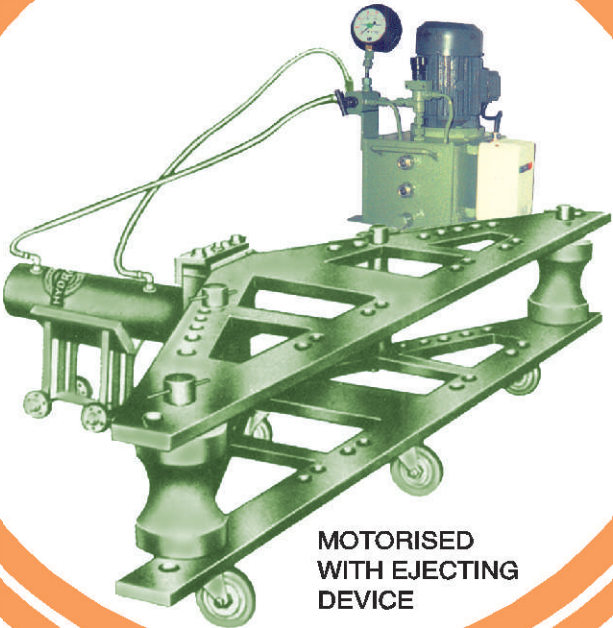

MOTORISED
WITH EJECTING
DEVICE

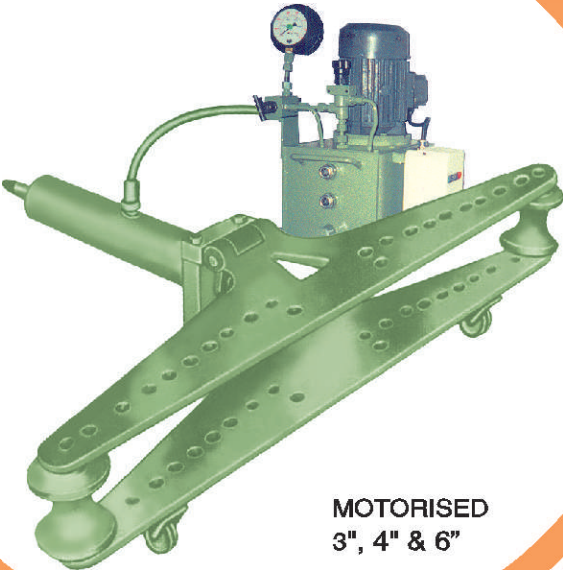

MOTORISED
3", 4" & 6"

HYDROBEND

MECHANICAL PIPE BENDING MACHINES



CONDUIT PIPE BENDING MACHINE

Conduit Pipe Bending Machine for 14 to 24 Gauge Aluminium, Copper & Steel Pipes complete with formers of 5/8", 3/4", & 1" or any three formers up to 1" (We can arrange to supply formers in sizes of your requirement up to 1.1/4")



DEGREE TYPE MECHANICAL PIPE BENDING MACHINE

Mechanical degree type pipe bending machine. Size 5/8" to 1.1/4" complete with Std. formers of 5/8", 3/4", 1" and 1.1/4" and degree setting arrangement



MINI BENCH TYPE CONDUIT PIPE BENDING MACHINE

Size : 5/8" to 1" Complete with standard formers of 5/8", 3/4" & 1"

SPECIFICATIONS FOR HYDRAULIC HAND OPERATED PIPE BENDING MACHINES

Capacity	3/8" to 1"	1/2" to 2"	1/2" to 3"	1/2" to 4"	2" to 6"
Pressure in Tons	10	15	15 .	20	30
Formers of C" Class Pipes	3/8", 1/2", 3/4" & 1"	1/2", 3/4", 1", 1.1/4", 1.1/2", & 2"	1/2", 3/4", 1", 1.1/4", 1.1/2", 2", 2.1/2", & 3"	1/2", 3/4", 1", 1.1/4", 1.1/2", 2", 2.1/2", 3", & 4"	2", 2.1/2", 3", 4", 5" & 6"
Extension	-X-	-X-	Yes	Yes	Yes
Standard Accessories	Two Dolly Blocks with Pins and three leg Stand			Two Dolly Blocks with Pins and on Castor Wheels.	

Ejectomatic type hand operated pipe bending machine available in 3", 4" & 6" capacity, with above specifications

MOTORISED MACHINES

H.P. of the motor with starter: 2 2 3

Ejecting device for pipes available at extra price in Motorised Machines

8" 8" Motorised Machine with ejecting device only

MOTORISED Formers: 2", 2.1/2", 3", 4", 5", 6" & 8".

PIPE BENDER Motor : 5 H.P. With Starter.

Formers for B' class pipes upto 3" and For A' class pipes upto 2" available at extra price.

***buy hydrobend pipe benders for its competitive price.
superb quality & excellent service after sales.***