

# TMS 750B MK II

## Product Guide



HYDRAULIC TRUCK CRANE

### Features

- MAX. CAPACITY (Outriggers) - 40 Tonnes at 3m Radius (85% Rating) 360° Slew
- BOOM - 4 SECTION Trapezoidal 10.6m - 33.5m
- MAX. ROAD SPEED - 49 km/hr
- CARRIER - 8 x 4 Drive

# Superstructure Specifications

## BOOM

4-section, telescopic, trapezoidal, full power, sequenced-synchronized boom. Fabricated from high strength low alloy steel plates. Telescopic sections slide on adjustable and replaceable low friction wear resistance pads.

**Telescoping Range:** 10.6m - 33.5m

**Maximum tip height:** 35.9m

## BOOM NOSE

Four nylatron sheaves mounted on heavy duty tapered roller bearings with removable pin-type rope guard.

## BOOM DERRICKING

Single double acting hydraulic cylinder with integral holding valve.

## BOOM ANGLE

Maximum 78°, Minimum -2.4°.

## SUPERSTRUCTURE FRAME

Fabricated from high tensile steel plates and sections.

## SLEW SYSTEM

Ball bearing swing circle with 360° continuous rotation. Planetary "Glide-Swing" with foot applied multi-disc wet brake. Spring applied hydraulically released parking brake. Mechanical house lock operated from cab. Free slew facility provided.

## SLEW SPEED

Limited to 2 rev./min. (Unladen) for controlled operation.

## HOIST SYSTEM

Power up and down, equal speed, planetary reduction with integral automatic spring applied multidisc brake on grooved hoist barrel. Hoist drum fitted with third wrap indicator.

**Non Spin Hoist Rope:** 19mm (3/4") dia & length 152m.

**Max. Permissible Line Pull:** 5860kg.

**Line Speed:** 75m/min. (Unladen)- Top layer.

## HOOK BLOCK

45 MT, 4 sheaves.

## COUNTERWEIGHT

Bolted to Superstructure.

Weight - 6113Kg.

## CRANE CONTROLS

Joystick controls are in operator's cab for slewing, telescoping, hoisting and derricking with independent or simultaneous operation of crane motions.

## HYDRAULIC SYSTEM

**Pump** – 3 Sec. gear pump driven through gearbox PTO Engine driven steering pump.

**Valves** – 3 nos. Over centre control valves with built-in pressure relief.

**Filter** – Return line type, full flow with bypass protection and service indicator. Replaceable cartridge.

**Reservoir** – 390 liters capacity fitted with filter, external sight gauge, clean out access, strap mounted to frame.

**Oil Cooler** – Remote mounted, thermostatically controlled electric motor driven fan.

## LOAD MOMENT INDICATOR & ANTI-TWO BLOCK SYSTEM

Electronic load moment indicator system with audio-visual warning & control lever lockout indicates electronic display of boom angle, length, radius, relative load moment, permissible load, load indication & warning of impending two block condition. Motion cut off to ensure the safe operation with load for tele, derrick & hoist motions.

## SAFETY SYSTEM

Pendent Limit Switch on boom head for over hoist. Third wrap indicator on hoist barrel to ensure 3 turns of rope on hoist drum. Hydraulic relief valves protect pumps and structures from excessive pressure. Lock and counterbalance valves fitted on derrick, telescopic and outrigger cylinders to sustain rams in the event of hydraulic failure.

## OPERATOR'S CAB

Totally enclosed steel construction, full vision type, windows fitted with toughened safety glass including front windscreen. Adjustable operator's seat, cab interior light, electric fan, electric horn, electric windshield wiper and lockable sliding door. Ergonomically designed cab and controller layout to give fatigue free operator's comfort.

## OPTIONAL EQUIPMENT

9.7m Fixed Swingaway Extension

Auxiliary Hoist

Single Sheave Hookblock - 15 MT

Fire Extinguisher

Rotating Beacon Lamp

Spark Arrestor

Headache Ball - 10 MT

# Height of Lift: 4 Section 10.6m - 33.5m Full Power Boom

WORKING RANGE DIAGRAM  
(BOOM DEFLECTION NOT SHOWN)

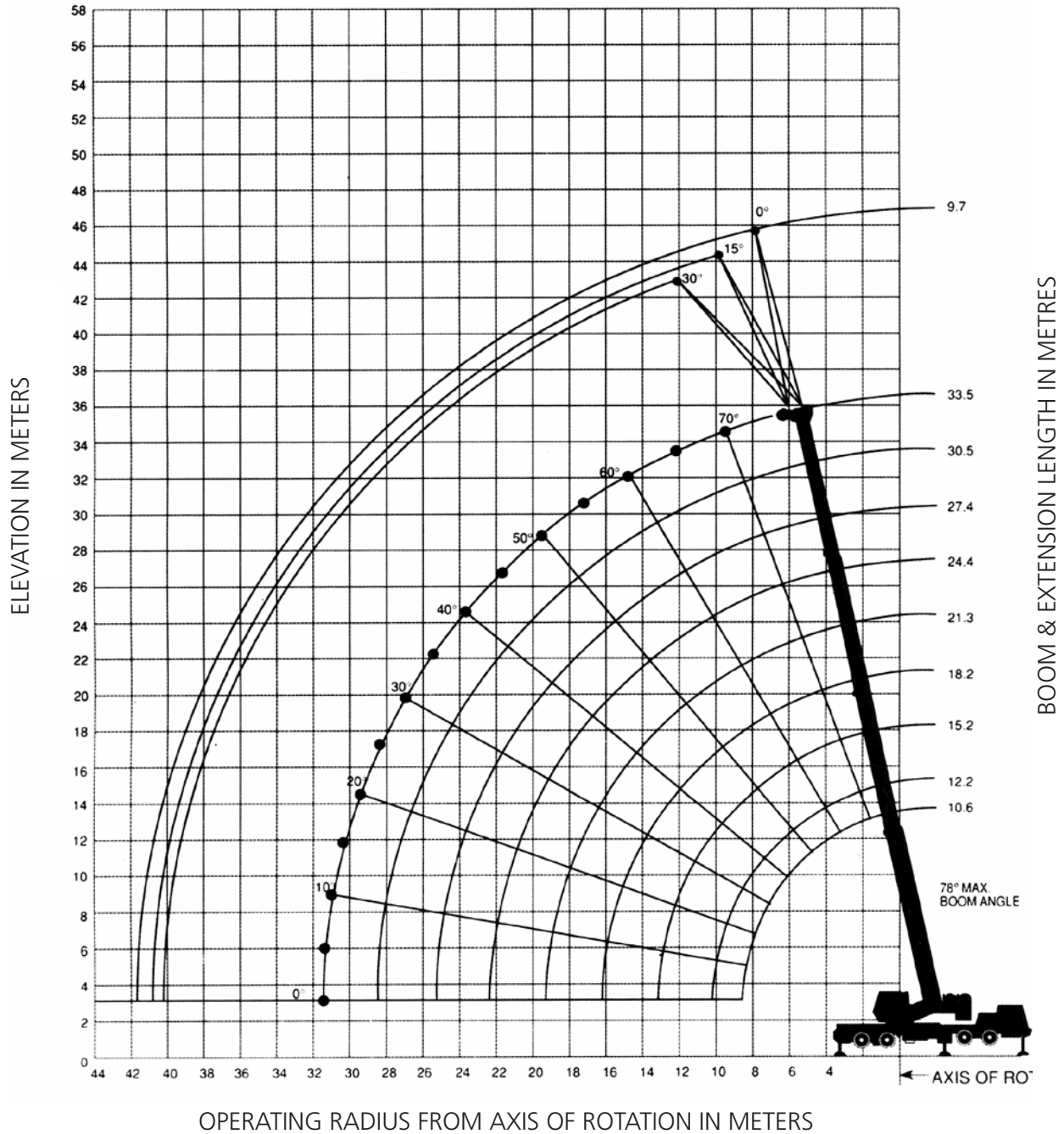

NOTE:  
The above heights of lift and boom angles are based on a straight (unladen) boom and allowance should be made for boom deflections obtained under laden conditions.



# Metric 85% Lifting Capacities (Kilograms) on Outriggers Fully Extended

## Main Boom - On Outriggers Fully Extended - 360°

Radius in Meters (m)	Main Boom Length in Meters								
	10.6	12.2	15.2	*18.2	21.3	24.4	27.4	30.5	33.5
3	40,000 (66)	30,975 (69.5)	26,475 (74)						
3.5	31,875 (63)	29,400 (67)	25,450 (72)	20,250 (75.5)					
4	28,725 (60)	27,550 (64.5)	24,300 (70)	19,825 (73.5)					
4.5	26,600 (56.5)	25,400 (61.5)	23,400 (68)	19,250 (72)	16,150 (75)	14,950 (77)			
5	24,525 (53)	23,500 (58.5)	22,500 (66)	17,975 (70.5)	15,700 (73.5)	14,300 (76)			
6	21,500 (45)	21,100 (52.5)	21,000 (61.5)	15,475 (67)	13,975 (70.5)	12,825 (73.5)	11,550 (75.5)	10,550 (77.5)	
6.5	20,500 (41)	20,500 (49.5)	20,500 (59.5)	14,425 (65)	13,125 (69)	12,125 (72.5)	11,075 (74.5)	10,150 (76.5)	
7	18,000 (36)	18,000 (46)	18,000 (57)	13,550 (63.5)	12,350 (67.5)	11,500 (71)	10,600 (73.5)	9,755 (75.5)	8,390 (77.5)
8	13,950 (23)	15,000 (38.5)	15,000 (52)	12,025 (59.5)	10,900 (64.5)	10,375 (68.5)	9,650 (71.5)	8,910 (73.5)	8,060 (75.5)
9		13,375 (29)	13,000 (47)	10,750 (56)	9,740 (61.5)	9,380 (66)	8,860 (69)	8,070 (71.5)	7,265 (73.5)
10		8,385 (11.5)	10,950 (41)	9,690 (51.5)	8,765 (58.5)	8,465 (63)	7,985 (66.5)	7,340 (69.5)	6,595 (72)
12			8,045 (26)	7,875 (42.5)	7,235 (51.5)	6,965 (57.5)	6,545 (62)	6,140 (65.5)	5,530 (68)
14				5,820 (31.5)	6,030 (44)	5,845 (51.5)	5,470 (57)	5,115 (61)	4,720 (64.5)
16				3,650 (11)	4,705 (35)	4,970 (45)	4,640 (51.5)	4,320 (56.5)	4,080 (60.5)
18					3,650 (22.5)	3,900 (37.5)	3,975 (46)	3,685 (51.5)	3,480 (56)
20						3,060 (28)	3,260 (39)	3,165 (46.5)	2,980 (51.5)
22						2,400 (11.5)	2,610 (31.5)	2,735 (40.5)	2,565 (47)
24							2,080 (21)	2,230 (34)	2,210 (42)
26								1,800 (25.5)	1,910 (36)
28								1,435 (12)	1,545 (29)
30									1,230 (19.5)
Minimum boom angle (deg.) for indicated length (no load)									0
Maximum boom length (m) at 0 deg. boom angle (no load)									33.5

Note : ( ) Boom angles are in degrees.

## Lifting Capacities on Outriggers Fully Extended - 360° At Zero Degree Boom Angle

Boom Angle	Main Boom Length (in Meters)								
	10.6	12.2	15.2	*18.2	21.3	24.4	27.4	30.5	33.5
0°	7,030 (8.5)	5,555 (10.1)	3,565 (13.1)	2,250 (16.1)	1,665 (19.2)	1,225 (22.3)	885 (25.3)	615 (28.3)	400 (31.3)

Note: ( ) Reference radii in meters

\*18.2 m boom length is with inner-mid extended and outer-mid & fly retracted

## Notes for Lifting Capacities

**WARNING: THIS CHART IS ONLY A GUIDE.** The Notes below are for illustration only and should not be relied upon to operate the crane. The individual crane's load chart, operating instructions and other instruction plates must be read and understood prior to operating the crane.

- All rated loads have been tested to and meet minimum requirements of IS: 4573-1982 Specification for Power Driven Mobile Cranes, and do not exceed (85% of the tipping load on outriggers as well as on rubber) as determined by SAE J765 OCT 80 Crane Stability Test Code.
- The weight of hook-block, slings and all similarly used load handling devices must be added to the weight of the load. When more than minimum required reeving is used the additional rope weight shall be considered part of the load.
- Capacities appearing above the bold line are based on structural strength and tipping should not be relied upon as a capacity limitation.
- All capacities are, for crane on firm, level surface. It may be necessary to have structural supports under the outrigger floats or tires to spread the load to a larger bearing surface.
- When either boom length or radius or both are between values listed, the smallest load shown at either the next larger radius or boom length shall be used.
- For outrigger operation, all outriggers shall be fully stretched & jacks extended to raise tires free of the ground & the slew plinth becomes horizontal before raising the boom or lifting loads.
- The machine is equipped with front jack, the front jack cylinder shall be set along with the four outriggers.
- Tires shall be inflated to the recommended pressure before lifting on rubber. Capacities must be reduced for lower tyre inflation. Damaged tyres are hazardous for safe operation of crane.
- For Pick & Carry operation, boom must be centered over rear of machine, mechanical swing lock engaged and load restrained from swinging.
- Lifting over-side on rubber is not permitted. Outrigger beams must be fully extended and stabilizers properly set when rotating superstructure over the side.
- Do not travel with crane boom extension or, jib erected.
- Load ratings are based on freely suspended loads. No attempt shall be made to move a load horizontally on the ground in any direction.
- Handling of other equipment with the boom is not authorized except with equipment furnished and installed by TIL Ltd.
- 9.7m Fixed offsetable boom extension warning. For main boom length greater than 27.4 m with 9.7 m fixed boom extension in working position, the boom angle must not be less than 31°, since loss of stability will occur causing a tipping condition. The boom angle is not restricted for main boom length equal to or less than 27.4 m. This warning also applies for boom extension erection purposes.

# Lifting Capacities (Kilograms)

## 9.7 m Fixed Length Lattice Extension on Outriggers Fully Extended-360°

Radius (in Meters)	0° Offset	15° Offset	30° Offset
9	*4,475 (78)		
10	4,275 (77)	*3,570 (78)	
12	3,835 (74)	3,395 (76)	*2,800 (78)
14	3,445 (71.5)	3,210 (73)	2,730 (75.5)
16	3,100 (68.5)	3,040 (70.5)	2,580 (72.5)
18	2,720 (65.5)	2,895 (67.5)	2,455 (69.5)
20	2,335 (62.5)	2,525 (64)	2,345 (66.5)
22	1,995 (59)	2,175 (61)	2,235 (63.5)
24	1,700 (55.5)	1,860 (58)	1,990 (60)
26	1,430 (52)	1,570 (54.5)	1,690 (56.5)
28	1,195 (48.5)	1,320 (50.5)	1,420 (53)
30	980 (44.5)	1,090 (47)	1,175 (49)
32	790 (40.5)	885 (42.5)	955 (45)
34	610 (36)	690 (38)	745 (40)

NOTE: ( ) Boom angles are in degree.

\*The capacity is based upon the maximum boom angle.

## Weight Reductions for Load Handling Devices (Approx.)

Hookblocks and Headache Ball	
4 Sheave Hook block - 45T	500 kg
Single Sheave Hook block - 15 MT	418 kg
Headache ball - 10 MT	227 kg
9.7m Fixed Extension	
*Stowed	122 kg
*Erected	1,928 kg

\*Reduction of main boom capacities

## Hookblock Capacities and Weights – Tonnes

No of Falls	8	7	6	5	4	3	2	1
Permissible Load	40.0	34.5	29.7	25.0	20.1	15.2	10.3	5.0
Weight of Hookblock	0.5	0.5	0.5	0.5	0.5	0.5	0.418	0.22

## Main Boom (On Rubber) – Rear

Radius (in Meters)	10.6 m Boom	
	Boom Over Rear only	
	Static	Up to 2 km/hr
3	10000	7000
4	9000	6500
5	8000	6000
5.5	7500	5500
6	7000	5000
6.5	6000	4500
7	5500	3000
8	4500	2000

Recommended Tyre Pressure – Front - 8.1 kg/cm<sup>2</sup>  
Rear - 7.0 kg/cm<sup>2</sup>

	No Load Stability Data	Main Boom 33.5m
Rear	Min. boom angle (deg.) for indicated length	31°
No Load	Max. boom length (m) at 0° boom angle	27.4m

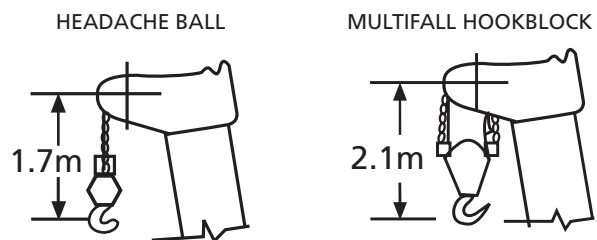

Dimensions are for largest furnished hook block and headache ball with anti-two block activated.

# Carrier Specification

## CARRIER

8 x4 wheel right hand drive, purpose built heavy duty carrier frame of torsion box section with integral front & rear outrigger housing fabricated from high strength steel plates and sections.

## OUTRIGGERS

Hydraulically operated outrigger system, comprising four independently controlled hydraulic telescopic horizontal beams with vertical jacks for over side & over rear operation. Plus one vertical hydraulic jack mounted under front of carrier to permit 360° lifting duties. Outrigger hydraulic jacks are fitted with positive lock valves. Easy fit outrigger feet are provided with stowage facility on carrier.

## OUTRIGGER CONTROLS

Located in the superstructure cab on front dash panel, requires two hand operation. Crane level indicator adjacent to controls.

## ENGINE

Ashok Leyland H6 Series,  
165 kW @ 2500 RPM,  
Max. Torque : 800 Nm @ 1700 - 1900 RPM  
Emission : BS III CEV

## CLUTCH

Dry single plate hydraulically operated servo assisted.

## GEAR BOX

Synchromesh, 9 forward & 1 reverse speed obtained via a single lever control.

## DRIVE CONFIGURATION

8 x 4

## AXLES

**Front Axle** – 2 beam type non-drive steer axles, leaf spring mounted in tandem.

**Rear Axle** – 2 Heavy duty, fully floating type with hub reduction, twin axle. Air operated inter axle differential lock. Mounted on specially designed rocker beam to allow maximum articulation on uneven ground.

## STEERING

Front axles, mechanical with hydraulic power assist controlled by steering wheel from driver's cab.

## BRAKES

**Service** – Air operated on all wheels by means of foot operated pedal in driver's cab.

**Parking** – Flick-valve operated, spring actuated pneumatically released brake on trailing front axle and leading rear axle.

## FUEL TANK

Capacity – 300 liters

## WHEELS & TYRES

Tyres 11.00 x 20-16PR or 11.00R20-16PR single on front axles and twins on rear axles.

Spare wheel (one) provided for front axle.

## DRIVER'S CAB

Two man design, steel construction full width cab with electric fan, interior light, horn, operating windows fitted with toughened glass. Two lockable doors, electric windscreen wiper in front of windscreen.

Upholstered and adjustable operator's seat. Automotive controls which include steering wheel, pedals for clutch, brake and accelerator.

## INSTRUMENTATION

Air pressure gauge, engine oil pressure gauge, fuel gauge, water temperature gauge, speedometer, voltmeter, tacho-hourmeter, warning lights and switches for control.

## ELECTRICAL EQUIPMENT

24-Volt starting and lighting system includes two combined dipping head lamps, side, rear and stop lamp, flashing direction indicator.

## TOOL BOX

Tool kit for normal maintenance.

## MAXIMUM SPEED

49 km/hr.

## GROSS VEHICLE WEIGHT AND AXLE LOADS (approx)

Front Axles	- 11,110 kg
Rear Axles	- 22,910 kg
GVW	- 34,020 kg

## Optional Weights (approx.)

Fixed Lattice	: 1000 kg
Auxiliary Hoist	: 700 kg

# G.A Drawing

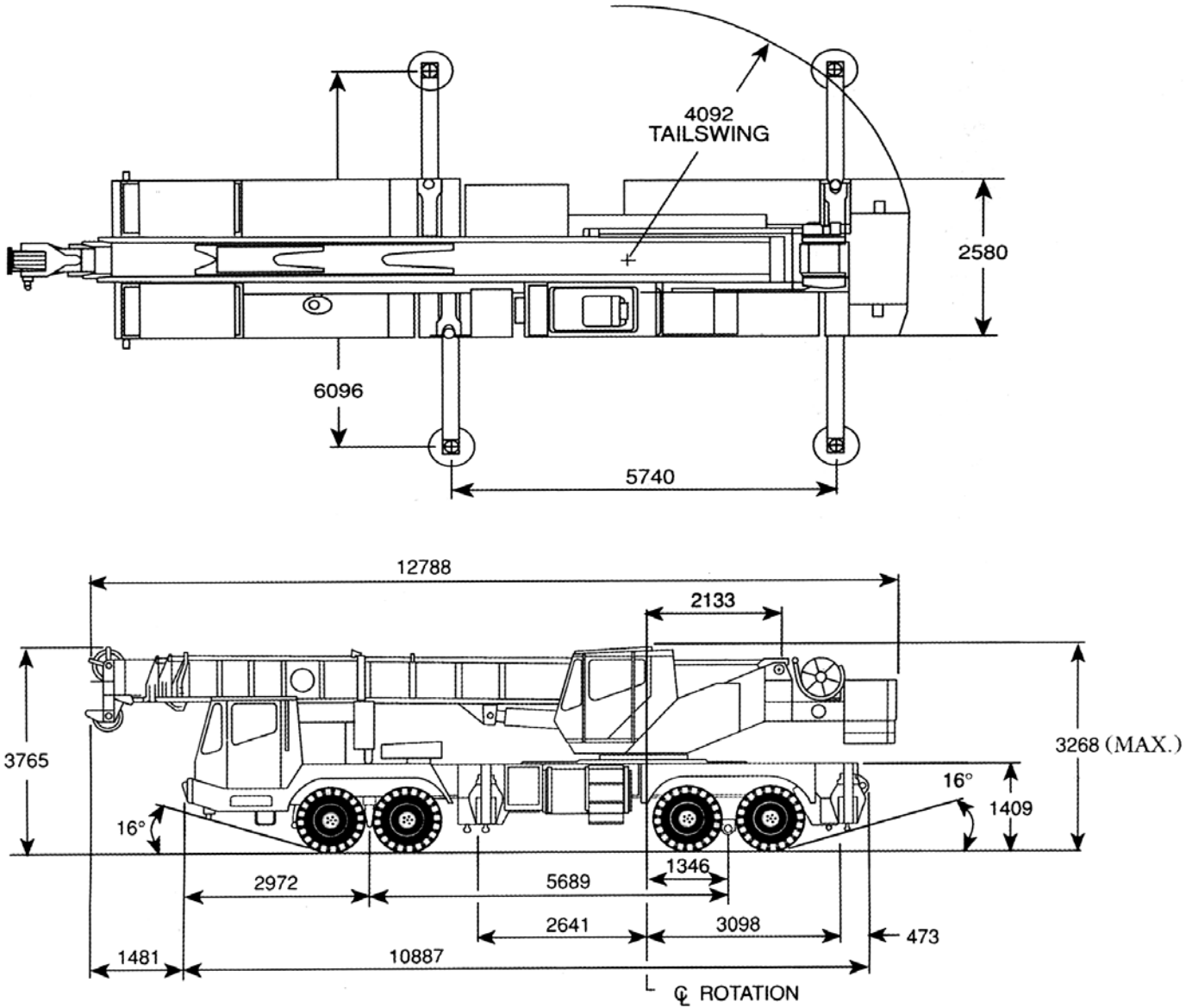

Constant improvement and engineering progress make it necessary that we reserve the right to make specification, equipment and price changes without notice. The photographs/drawings in this document are just for illustrative purpose which may include optional equipment and accessories, which can be provided at an additional cost on request.

## TIL Limited

CIN: L74999WB1974PLC041725

### Registered & Corporate Office:

1, Taratolla Road, Garden Reach, Kolkata - 700024  
Phone: + 91 33 2469 3732-6 / 6497 | 6633 2000 / 2845  
Mobile: +91 9831839025 | +91 9831054573  
Fax: + 91 33 2469 2143 / 3731  
Email: Mhg.Er@tilindia.com | mktg-til@tilindia.com



### CHENNAI

TIL Limited  
Jhaver Plaza, 7th Floor 1-A Nungambakkam  
High Road  
Chennai 600 034, Tamil Nadu  
Phone: +91 044 6670 3000 / 3010  
Mobile: +91 9618562333 | +91 9790973502  
Fax: +91 44 2827 9681  
Email: chennai.til@tilindia.com

### DELHI NCR

Plot 11, Site No.IV  
Sahibabad Industrial Area  
Ghaziabad 201 010 U.P.  
Phone: +91 120 277 8735 / 8736 / 7468  
Mobile: +91 9971091610 | 9903842544  
Fax: +91 120 277 7467  
Email: MHGMarketing.Sahibabad@tilindia.com | mhgcs.Sahibabad@tilindia.com

### DELHI

TIL Limited  
302 Ansal Bhawan  
16, Kasturba Gandhi Marg, New Delhi 110 001  
Phone: +91 11 2331 1607 / 8046 / 9248 | 2335 0250 / 0255  
Fax: +91 11 2331 3263  
Email: til.delhi@tilindia.com

### KAMARHATTY

TIL Limited  
517, Barrackpore Trunk Road  
Kolkata 700 058  
Phone: +91 33 2553 1352 / 1882 | 6633 4000  
Fax: +91 33 2553 2546 / 5971  
Email: MktDept.KMT@tilindia.com | til.kmt@tilindia.com

### KHARAGPUR

TIL Limited  
Vill. & P.O. Changual, Kharagpur  
Dist: Paschim Medinipur 721 301, West Bengal  
Phone: +91 32 2266 1101

### MUMBAI

TIL Limited  
502 - A, 5th Floor, Western Edge Tower No.1  
Western Express Highway, Datta Pada Road  
Borivali (East), Mumbai 400 066, Maharashtra  
Tel: 91 022 6147 9159 / 9135 / 9143 / 9133 / 9137  
Mobile: +91 99301 11962 | 98926 79925 | 88509 71609  
Fax: 91 22 6147 9111  
Email: Mumbai.TIL@tilindia.com | Mumbai.Custsupp@tilindia.com

**TIL has a pan-India network of offices with service engineers located in the close proximity of jobsites.**

Toll Free No: **1800 266 1535**

**www.tilindia.in**

Technical Specification TIL/TMS750B MK III/0318. This cancels Technical Specification TIL/TMS750B MK III/1117